



The Professional Choice

EHV/EHVF

Bladder Accumulators



OLAER EHV/EHVF | High pressure bladder type conforming to EC regulations



Increasing the safety of your systems !

The accumulators installed in energy storage make your systems safe in case of failure to one of the components.

Examples :

- Emergency braking of special vehicles
- Pitching the blades on wind turbines

Preserving the environment !

- By using renewable energy : The transformation of wave energy into electricity is done via storing hydraulic energy in high and low pressure accumulators.
- By recovering the energy from the braking vehicle : The energy stored allows restarting the vehicle, thus lowering its fuel consumption.

Increasing the production capacity !

The installation of accumulators on the hydro-electric power station allows reduced pump power, thus lowering the electric consumption.

Lowering production costs !

Without changing the installed power, the installation of accumulators on a production machine can allow an increased frequency, for example, by accelerating the movement of displacement without hydraulic press stress.



Main Features

Operating principle

Operation of the OLAER gas loaded bladder accumulator is based on the considerable difference in compressibility between a gas and a liquid, enabling a large quantity of energy to be stored in an extremely compact form. This enables a liquid under pressure to be accumulated, stored and recovered at any time.

Its special design allows the bladder (the strategic component) to compress the gas and usually form into three lobes in order for the accumulator to store, then to deliver the fluid under pressure, as required.

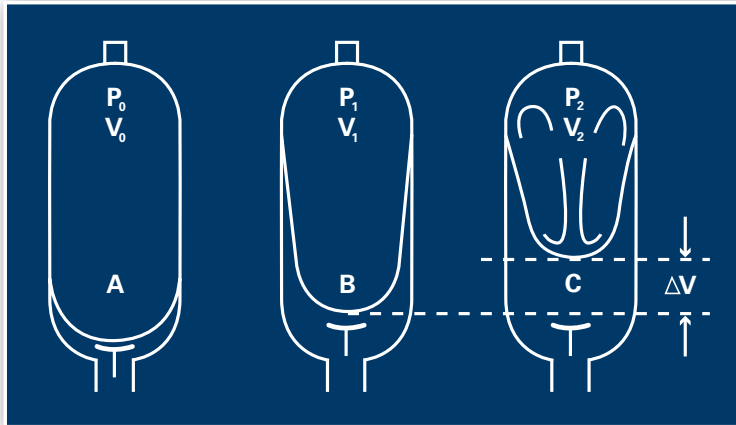

V_0 = Nitrogen capacity of the accumulator
 V_1 = Gas volume at the minimum hydraulic pressure
 V_2 = Gas volume at the maximum hydraulic pressure
 ΔV = Returned and/or stored volume between P_1 and P_2
 P_0 = Initial preload of the accumulator
 P_1 = Gas pressure at the minimum hydraulic pressure
 P_2 = Gas pressure at the maximum hydraulic pressure

A - Bladder in the precharge position, which means that it is only filled with nitrogen. The anti-extrusion system closes the hydraulic orifice and prevents the destruction of the bladder.

B - Position at the minimum operating pressure ; there must be a certain amount of fluid between the bladder and the hydraulic orifice, such that the anti-extrusion system does not close the hydraulic orifice. Thus, P_0 must always be $< P_1$.

C - Position at the maximum operating pressure. The volume difference ΔV between the minimum and maximum positions of the operating pressures represents the working fluid quantity.

Maximum pressure differential : 4:1

Your Benefits

- To increase your production rates thanks to large instantaneous flow rates that only accumulators can provide.
- Some spare power available at any time.
Example : EHV 50-330/90
Average flow : 650 L/min
Maximum pressure available: 320 Bar
Minimum pressure available: 250 Bar
Average power = Average flow x
Average pressure/600 = 308 kW
- The accumulator's ability to run independently reduces the installation cost while reducing your equipment running cost.
- With an accumulator in compliance with the European standard, your OLAER accumulator is suitable for use in more than 35 countries making it boundary friendly.



Technical Characteristics

The accumulator comprises a forged steel shell, a rubber bladder and a fluid port assembly.

- Shell material options include alloyed steel, stainless steel, aluminium, titanium and composites.
- Various bladder materials available which are compatible with a range of fluids and temperatures.
- Anti-extrusion system; fluidport assembly for high pressure.

Taking into account the different needs of various applications, Olaer offers different protections external and/or internal: Bare metal, nickel plating, epoxy paint, PTFE, Rilsan® and phenolic coating.

This extensive range enables us to offer accumulators operating from -50 to $+150^{\circ}\text{C}$ with pressures of up to 690 Bar and capacities of up to 57 litres.

As the market leader in bladder type accumulators, Olaer has participated in the development of the EN 14359:2006 standard, which specifies the material, design, manufacturing, tests, safety devices and documentation (including the instruction manual), for pressure accumulators and gas bottles for hydraulic applications.

How to size?

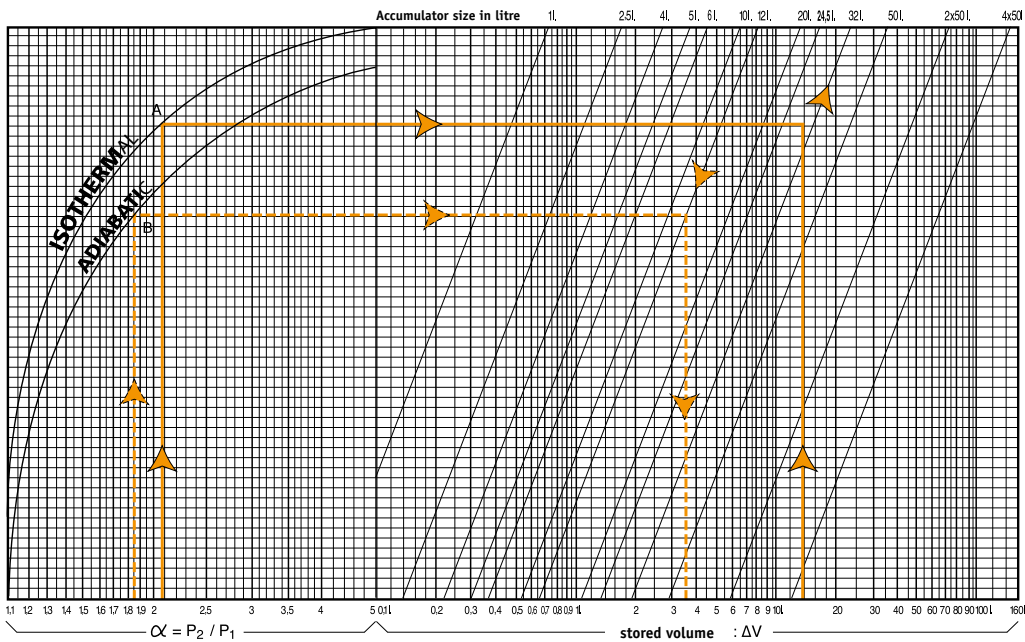

Basic sizing chart for accumulator used in energy storage.

Olaer has developed very sophisticated simulation software to optimize accumulator sizing recommendations. The behaviour of accumulators used in applications such as pulsation dampening, surge alleviation, thermal expansion and energy storage can be simulated. Our software is available on CD-Rom and can be downloaded from our website. You may also contact your local Olaer office for sizing assistance.



The above graph is useful to estimate the size of an accumulator used to store or deliver a specific volume of liquid within a given pressure range. These curves are the graphic representation of an adiabatic cycle (fast cycling rate - $N = 1.4$ perfect gas assumption) or isothermal cycle for an accumulator working at 20°C with a precharge $P_0 = 0,9 P_1$.

They do not take into consideration the real gas compression correction factor, the real adiabatic coefficient and the polytropic rate of the application. Depending on the application data, the influence of these factors may be significant, and require that some calculations adjustments be made. The Olaer simulation software takes all these factors into account.

Sizing of an accumulator to be installed in the following example conditions:

- P2 : Maximum available pressure : 210 Bar
- P1 : Minimum working pressure : 100 Bar

P0 : Nitrogen precharge : 90 Bar

ΔV : Volume to be stored : 14L

Condition : Isothermal (No temperature variation)

A/Compression ratio $\alpha = P_2/P_1 = 210/100 = 2,1$

B/From the value 2,1 on the α axis, draw a vertical line that intersects the isothermal reference curve in A.
C/From the value 14 on the ΔV axis, draw a vertical line. The intersection point of this line with the horizontal line meeting A indicates a required accumulator size of 32 L.

Calculation of the volume drawn off from an accumulator.

Accumulator size = 12 L

P2 = 185 Bar; P1 = 100 Bar;

P0 = 90 Bar; Adiabatic condition

$\alpha = P_2/P_1 = 185/100 = 1,85$

ΔV : 3,5 litres

*Reminder

Isothermal: The transformation is said to be isothermal when the compression or expansion of the gas occurs at a rate slow enough to allow a good thermal exchange, allowing the gas to remain at constant temperature.

Adiabatic: The transformation is said to be adiabatic when the cycle is quick and does not allow a temperature exchange with the ambient media.

Technical Characteristics

EHV RANGE FROM 0.2 TO 10 LITRES

Range 350 bar

Type	Effective Gas vol. Litres	Work pressure bar	Max Flow Rate lt/min	Max Weight in Kg	Clamps x (quantity)	O-ring + anti-extrusion ring	Support bracket	Fixation assembly	Dimensions in mm							
									A max height	B	C	øD max	ød	øE	F connection	SW ₁ on flats
EHV 0,2 - 350/90	0.17	350	120	2.1	A 56x1	consult page 11	-	-	266	38	29	58	16	38	G 1/2"	24
EHV 0,5 - 350/90	0.60	350	240	2.5	E 95x1		-	-	258	54	28	91	16	50	G 3/4"	32
EHV 1 - 350/90	1	350	240	6	E 114x1		CE 89	EF4	328	54	66	115	22.5	50	G 3/4"	32
EHV 1,6 - 350/90	1.6	350	240	8	E 114x1		CE 89	EF4	396	54	27	115	16	50	G 3/4"	32
EHV 2,5 - 350/90	2.4	350	450	11	E 114x2		CE 89	EF4	548	66	66	115	22.5	68	G 1 1/4"	50
EHV 4 - 350/90	3.7	350	450	15	E 168x1		CE 108	EF1	433	65	66	170	22.5	68	G 1 1/4"	50
EHV 5 - 350/90	5	350	450	19	E 114x2		CE 89	EF4	897	66	66	115	22.5	68	G 1 1/4"	50
EHV 6 - 350/90	6	350	450	20	E 168x1		CE 108	EF1	559	65	66	170	22.5	68	G 1 1/4"	50
EHV 10 - 350/90	10	350	450	31	E 168x2		CE 108	EF1	824	65	66	170	22.5	68	G 1 1/4"	50

Range 690 bar

Type	Effective Gas vol. Litres	Work pressure bar	Max Flow Rate lt/min	Max Weight in Kg	Clamps x (quantity)	O-ring + anti-extrusion ring	Support bracket	Fixation assembly	Dimensions in mm							
									A max height	B	C	øD max	ød	øE	F connection*	SW ₁ on flats
EHV 1 - 690/90	1.1	690	360	8,6	E 114x1	consult page 11	CE 89	EF4	376	68	69	122	22.5	68	G 1"	45
EHV 2,5 - 690/90	2.4	690	360	15	E 114x2		CE 89	EF4	551	68	69	122	22.5	68	G 1"	45
EHV 5 - 690/90	5	690	360	29	E 114x2		CE 89	EF4	900	68	69	122	22.5	68	G 1"	45

* Requires a special adapter

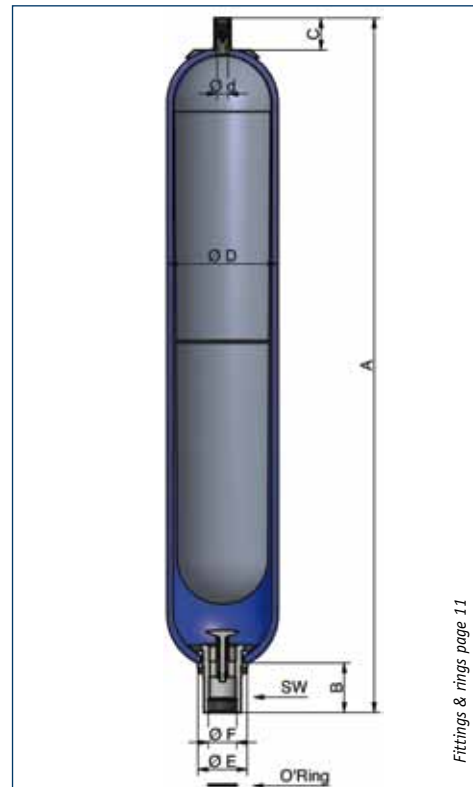

Fittings & rings page 11

Above dimensions are in mm and are subject to manufacturing tolerances.

EHV RANGE FROM 10 TO 50 LITRES

Range 330 bar

Type	Effective Gas vol. Litres	Work pressure bar	Max Flow Rate lt/min	Max Weight in Kg	Clamps x (quantity)	O-ring + anti-extrusion ring	Support bracket	Fixation assembly	Dimensions in mm							
									A max height	B	C	øD max	ød	øE	F connection	SW ₁ on flats
EHV 10 - 330/90	9.2	330	900	39	D 226x2	consult page 11	CE 159A	EF2	585	103	66	226	22.5	101	G 2"	70
EHV 12 - 330/90	11	330	900	48	D 226x2		CE 159A	EF2	685	103	66	226	22.5	101	G 2"	70
EHV 20 - 330/90	17.8	330	900	63	D 226x2		CE 159A	EF2	895	103	66	226	22.5	101	G 2"	70
EHV 24.5 - 330/90	22.5	330	900	74	D 226x2		CE 159A	EF2	1030	103	66	226	22.5	101	G 2"	70
EHV 32 - 330/90	32	330	900	103	D 226x2		CE 159A	EF3	1420	103	66	226	22.5	101	G 2"	70
EHV 50 - 330/90	48.5	330	900	142	D 226x2		CE 159A	EF3	1934	103	66	226	22.5	101	G 2"	70

Range 480 bar

Type	Effective Gas vol. Litres	Work pressure bar	Max Flow Rate lt/min	Max Weight in Kg	Clamps x (quantity)	O-ring + anti-extrusion ring	Support bracket	Fixation assembly	Dimensions in mm							
									A max height	B	C	øD max	ød	øE	F connection	SW ₁ on flats
EHV 10 - 480/90	9.2	480	900	40	D 226x2	consult page 11	CE 159A	EF2	592	103	74	228	22.5	101	G 2"	70
EHV 12 - 480/90	11	480	900	48	D 226x2		CE 159A	EF2	692	103	74	228	22.5	101	G 2"	70
EHV 20 - 480/90	17.8	480	900	66	D 226x2		CE 159A	EF2	902	103	74	228	22.5	101	G 2"	70
EHV 32 - 480/90	32	480	900	109	D 226x2		CE 159A	EF3	1427	103	74	228	22.5	101	G 2"	70
EHV 50 - 480/90	48.5	480	900	150	D 226x2		CE 159A	EF3	1965	103	97	228	50.8	101	G 2"	70

Range 690 bar

Type	Effective Gas vol. Litres	Work pressure bar	Max Flow Rate lt/min	Clamps x (quantity)	O-ring + anti-extrusion ring	Support bracket	Dimensions in mm							
							A max height	B	C included ring	øD max	ød	øE	F connection *	SW ₁ on flats
EHV 12 - 690/90	11	690	900	11060x2	consult page 11	11061	755	100	169	262	50	110	2"	77
EHV 20 - 690/90	16.5	690	900	11060x2		11061	965	100	169	262	50	110	2"	77
EHV 37 - 690/90	33.4	690	900	11060x2		11061	1490	100	169	262	50	110	2"	77
EHV 54 - 690/90	48	690	900	11060x2		11061	2004	100	169	262	50	110	2"	77

* Requires a special adapter

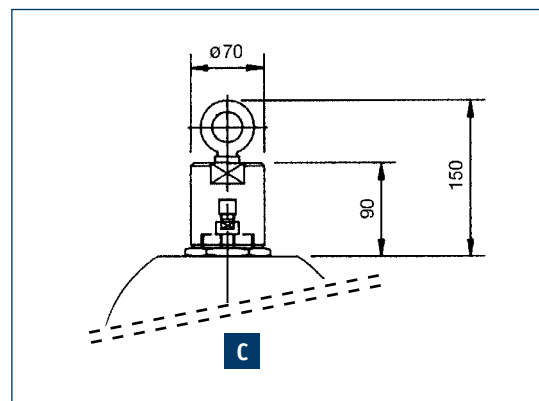

Above dimensions are in mm and are subject to manufacturing tolerances.

Technical Characteristics

EHVF RANGE FROM 2.5 TO 10 LITRES FLANGED

Range 350 bar

Type	Effective Gas vol. Litres	Work pressure bar	Max Flow Rate lt/min	Max Weight in Kg	Clamps x (quantity)	Connection (norme NFE 48055)	Support bracket	Fixation assembly	Kit of flange (page 11)	Dimensions in mm									
										A max height	B	C	øD max	øD	øE	øF	SW ₁ on flats	øL	M
EHVF 2,5 - 350/90	2.4	350	450	11	E 114x2	PN 400DN 25 or 1" SAE 6000 PSI	CE 89	EF4	BR 400-25	593	111	66	115	22.5	68	22	50	47.9	9.5
EHVF 4 - 350/90	3.7	350	450	15	E 168x2		CE 108	EF1	BR 400-25	478	110	66	170	22.5	68	22	50	47.9	9.5
EHVF 5 - 350/90	5	350	450	19	E 114x2		CE 89	EF4	BR 400-25	942	111	66	115	22.5	68	22	50	47.9	9.5
EHVF 6 - 350/90	6	350	450	20	E 168x2		CE 108	EF1	BR 400-25	604	110	66	170	22.5	68	22	50	47.9	9.5
EHVF 10 - 350/90	10	350	450	31	E 168x2		CE 108	EF1	BR 400-25	869	110	66	170	22.5	68	22	50	47.9	9.5

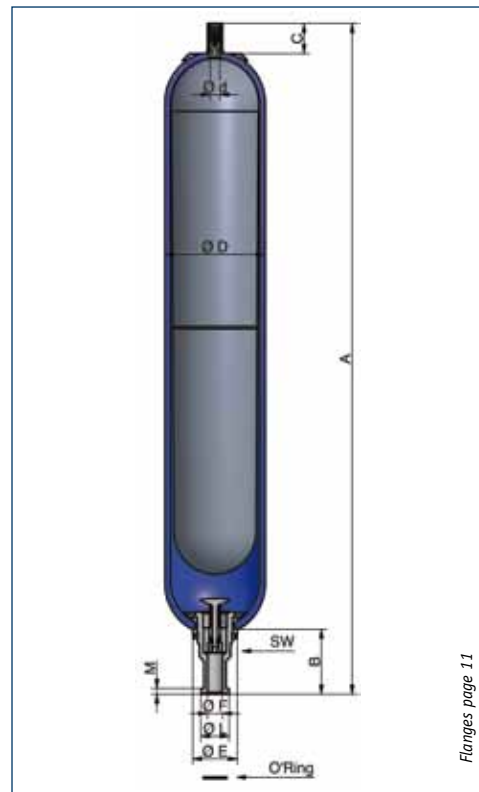

Above dimensions are in mm and are subject to manufacturing tolerances.

EHVF RANGE FROM 10 TO 50 LITRES FLANGED

Range 250 bar

Type	Effective Gas vol. Litres	Work pressure bar	Max Flow Rate lt/min	Max Weight in Kg	Clamps x (quantity)	Connection (norme NFE 48055)	Support bracket	Fixation assembly	Kit of flange (page 11)	Dimensions in mm									
										A max height	B	C	øD max	ød	øE	øF	SW ₁ on flats	øL	M
EHVF 10 - 250/90	9.2	250	900	39	D 226x2	PN 250DN 51 or 2" SAE 3000 PSI	CE 159A	EF2	BR 250-51	600	118	66	226	22.5	101	47	70	71.4	9.5
EHVF 12 - 250/90	11	250	900	48	D 226x2		CE 159A	EF2	BR 250-51	700	118	66	226	22.5	101	47	70	71.4	9.5
EHVF 20 - 250/90	17.8	250	900	63	D 226x2		CE 159A	EF2	BR 250-51	910	118	66	226	22.5	101	47	70	71.4	9.5
EHVF 24.5 - 250/90	22.5	250	900	74	D 226x2		CE 159A	EF2	BR 250-51	1045	118	66	226	22.5	101	47	70	71.4	9.5
EHVF 32 - 250/90	32	250	900	103	D 226x2		CE 159A	EF3	BR 250-51	1435	118	66	226	22.5	101	47	70	71.4	9.5
EHVF 50 - 250/90	48.5	250	900	142	D 226x2		CE 159A	EF3	BR 250-51	1949	118	66	226	22.5	101	47	70	71.4	9.5

Range 330 bar

Type	Effective Gas vol. Litres	Work pressure bar	Max Flow Rate lt/min	Max Weight in Kg	Clamps x (quantity)	Connection (norme NFE 48055)	Support bracket	Fixation assembly	Kit of flange (page 11)	Dimensions in mm									
										A max height	B	C	øD max	ød	øE	øF	SW ₁ on flats	øL	M
EHVF 10 - 330/90	9.2	330	900	39	D 226x2	PN 400DN 38 or 1 1/2" SAE 6000 PSI	CE 159A	EF2	BR 400-38	625	143	66	226	22.5	101	34	70	63.8	12.5
EHVF 12 - 330/90	11	330	900	48	D 226x2		CE 159A	EF2	BR 400-38	725	143	66	226	22.5	101	34	70	63.8	12.5
EHVF 20 - 330/90	17.8	330	900	63	D 226x2		CE 159A	EF2	BR 400-38	935	143	66	226	22.5	101	34	70	63.8	12.5
EHVF 24.5 - 330/90	22.5	330	900	74	D 226x2		CE 159A	EF2	BR 400-38	1070	143	66	226	22.5	101	34	70	63.8	12.5
EHVF 32 - 330/90	32	330	900	103	D 226x2		CE 159A	EF3	BR 400-38	1460	143	66	226	22.5	101	34	70	63.8	12.5
EHVF 50 - 330/90	48.5	330	900	142	D 226x2		CE 159A	EF3	BR 400-38	1974	143	66	226	22.5	101	34	70	63.8	12.5

Above dimensions are in mm and are subject to manufacturing tolerances.

Accessories

CLAMPS

Type	Form	Recommended min/max diameter	Dimensions in mm											Recommended tightening torque N.m.	
			A	B	C		D	E	F	G	H	I	J		K
					Min	Max									
A 56	E	54/56	92	102	36	36	3	37	M10x80	3	31	14	9	134	7
E 95	E	87/97	88	140	61.5	66.5	1.5	28	M8x75	3	40	35	9	155	7
E 114	E	112/124	88	140	73	78	1.5	28	M8x75	3	40	35	9	155	7
E 168	E	166/176	137	189	92	96	1.7	30	M10x80	3	45	35	9	210	10.5
D226	D	219/226	210	222	119	122.5	3	35	M12x80	3	40	21	15	270	11
F260	F	260	260	195	263	-	260	295	-	-	-	-	-	295	-

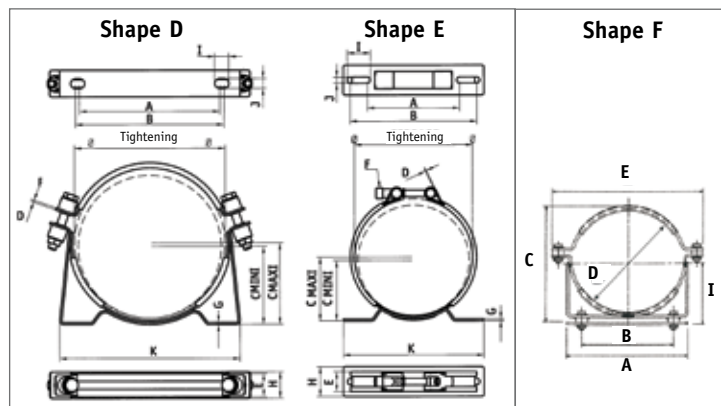

SUPPORT BRACKETS

Type	Shape	A	B	C	H	I	J	K	L	M	N	R	S	Weight
CE 89	A	89	101	125	73	140	75	13	25	60	75	130	-	0.8
CE 108	A	108	120	150	92	175	95	17	25	80	160	210	-	1.5
CE 159A	B	159	170	200	123	235	115	17	25	100	200	260	40	2.5
CE 11061	B	-	-	-	137	250	206	17	45	191	108	216	111	6

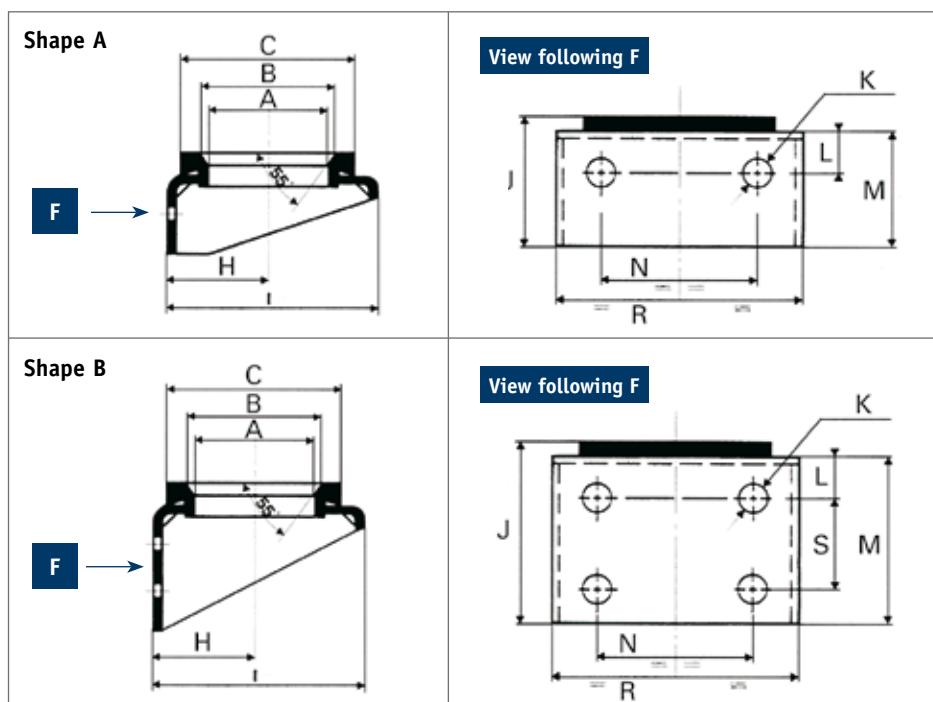

Above dimensions are in mm and are subject to manufacturing tolerances.

FITTINGS EHV

Accumulator model	Connection of accumulator ø F gas cyl.	Connection of fitting ø I gas cyl.	Shape	J/Flats	K	O-Ring & Back-up ring
EHV 0.5 & 1 & 1.6 Liters 350 Bar	3/4"	3/8"	A	-	8	O-Ring 21.3 x 2.4
		Blind	A	32		
EHV 2.5 to 10 Liters 350 Bar	1 1/4"	3/4"	A	50	10	O-Ring 36.2 x 3
		Blind	A			
EHV 0.2 Liter 350 Bar	1/2"	1/4"	A	27	8	O-Ring 18 x 2
		Blind	A			
EHV 1 to 5 Liters 690 Bar	1"	1/2"	B	41	10	O-Ring 21.3 x 3.6 BU R 22 x 28 x 2.69*2
		Blind	B			
EHV 10 to 50 Liters 330/480 Bar	2"	1"	A	65	13	O-Ring 54 x 3
		Blind	A			
EHV 10 to 50 Liters 690 Bar	2"	1"	B	65	15	O-Ring 43.82 X 5.33 BU R 45 x 54 x 0.85
		Blind	B			

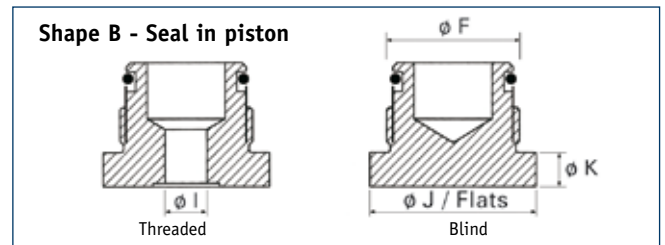
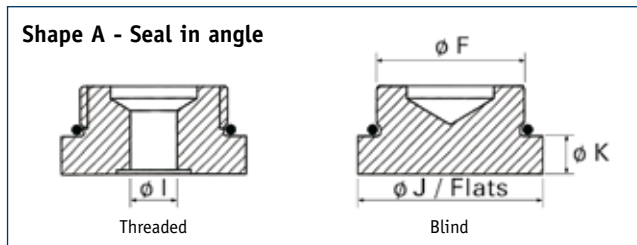

These accessories are designed to perfectly fit OLAER accumulators. They meet the latest regulations and are compliant with the CETOP standard.

FLANGES KITS EHV

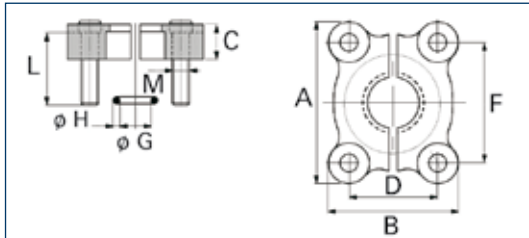

Type	A	B	C	D	F	ø G	ø H	L	M
BR 250-51	102	97	16	42.9	77.75	56.74	3.53	35	M14
BR 400-25	81	70	24	27.75	57.15	32.92	3.53	40	M12
BR 400-38	113	95	30	36.5	79.4	47.22	3.53	50	M16

FIXATION MOUNTING FRAMES

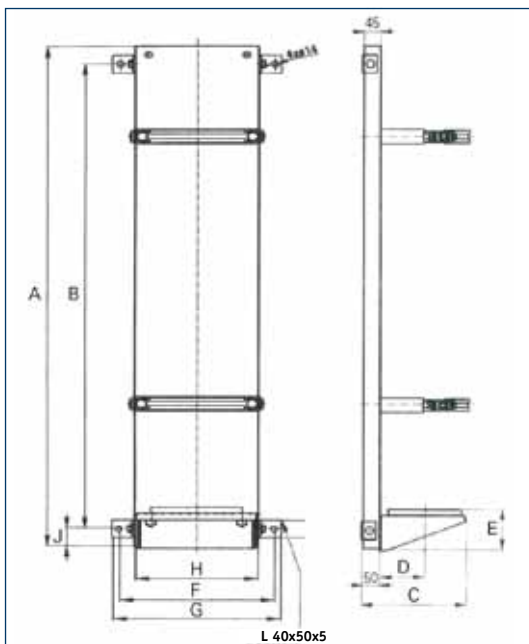

Type	A	B	C	D	E	F	G	H	J
EF1	670	570	225	92	96	340	370	270	50
EF2	670	570	285	123	115	340	370	270	50
EF3	1405	1300	285	123	115	340	370	270	55
EF4	750	600	190	73	85	208	238	138	50

Installed accumulator rack

Olaer design and manufactures modulare compact assemblies. For any request, please refer to Olaer technical services.



Above dimensions are in mm and are subject to manufacturing tolerances.

Accessories

Charging sets are used to inflate, check, top-up or vent the nitrogen gas precharge in all accumulators. They are to be screwed to the gas valve or bladder stem and connected to the gas regulator that fits the Nitrogen bottles. They are supplied in a plastic case.

MODEL VG3

For OLAER accumulators.

The standard set is delivered in a storage case containing the following:

- VG3 tester and pressurizer
- Pressure gauge kit from 0 to 250 bar
- 3 connection adapters for inflation valves (7/8"-14 UNF/5/8"-18 UNF/8 V1)
- High pressure hose, 2 m long, for connecting to a nitrogen source. The flexible tube is fitted with a female connector at both ends (60° BSP 1/4" connector for connection to the pressurizing port and connector dia 21,7 x 1,814 SI) with gasket for connection to a pressure source (commercial nitrogen cylinder, portable nitrogen station, superpressurizer, etc.).



Note:

The following options are available on request: Pressure gauge kits with different scale divisions. Scale divisions 0-6, 0-10, 0-60, 0-100, 0-160, 0-250, 0-400.

High pressure hose TS2 for maximum pressure 400 Bar.

Ordering code - Example: VG3 250 1 TS2 1

250 = Gauges, possible choice between pressure ranges

6/10/25/60/100/160/250/400

TS2 = Flexible hose for maximum working pressure 400 Bar

MODEL VGU

Universal charging set fits most of the hydraulic accumulators available on the market.

Maximum working pressure: limited by the maximum operating pressure of the installed pressure limited to 400 bar in any case.

The standard set is delivered in a storage case containing the following:

VGU universal tester and pressurizer (end M28x1.50)

- Pressure gauge kit from 0 to 25 bar
- Pressure gauge kit from 0 to 250 bar
- Connection adapters for inflation valves (7/8" - 5/8" - 8V1 - M28x1.50)
- High pressure hose, 2.5 m long, for connecting to a nitrogen source
- Hexagon socket screw key 6mm
- Seal Kit
- Operating instruction in French, English, German



Note:

The following options are available on request: Pressure gauge kits with different scale divisions: 63mm with glycerol filled back end G1/4" cyl. equipped with coupling for Minimes connection. Scale divisions 0-10, 0-60, 0-100, 0-400, with accuracy class 1.6%.

High pressure hose of different length with adapters for nitrogen bottles from various countries (specify country), at each end with a female swivel coupling G1/4" for connecting to the inflation port

Ordering code - Example: VGU/F 25/250 7 TS2 3

25/250 = Gauges, possible choice between pressure ranges 6/10/25/60/100/160/250/400

SAFETY BLOCKS

Are designed to incorporate in a single compact block a variety of functions necessary for the correct operation of a hydraulic system fitted with accumulators. This includes manual and/or electrical drain, isolation, flow control and pressure relief.

Channel cross section : 10 mm (DI 10 block), 16 mm (DI 16 block), 20 mm (DI 20 block), 24 mm (DI 24 block), 32 mm (DI 32 block).
Maximum working pressure : 330 to 690 Bar depending on models.
According with the fluids of group 2 (PED). Options for ATEX compliant blocks construction carbon steel or stainless steel.



A specific data sheet is available on request, please contact OLAER.

How to order?

ORDERING AN ACCUMULATOR

EHV 50 - 330/90 01125 Po=90b G1" cyl.

Accumulator Range

EHV : European High pressure bladder
EHVF : European High pressure bladder Flanged

Volume

in liters

Maximum working pressure

in Bar

Regulation code

90 : regulation EC

Construction

to be specified as per following recommendations table

Fluid	Working Temperature °C*	Construction
Mineral oils	-15 + 80	01125*
Water	0 + 50	01025
Water	0 + 80	01225
Ester phosphate	- 15 + 80	01140
Other fluids	Other temperatures	Please contact Olaer

* standard construction

Nitrogen gas precharge

in Bar at 20 °C (please refer to the predetermination curves table on page 5 or consult OLAER technical departments)

Adaptor to be specified

blind: with blank adaptor or without adaptor (refer to dimension I in table on page 11 and specify reduction size).

ORDERING AN ACCUMULATOR

Please indicate type for accessories as per tables on page 6 to 9, and for peripheral materials as per table on pages 10 and 11.

Installation

Position: Preferably vertical (liquid connection downwards) to horizontal, depending upon application. If the accumulator is installed in any position other than vertical with fluid port down, contact Olaer. The accumulator could have reduced volumetric efficiency and Olaer can help you to take these factors into account.

Mounting: A 200mm clearance is required above the accumulator to allow for gas charging. Each accumulator is delivered with a user instructions leaflet. Ensure that the pipes connected directly or indirectly to the accumulator are not subjected to any abnormal force, Ensure that the accumulator cannot move, or minimize any movement that may occur as a result of broken connections. Olaer clamps and brackets are designed for this purpose (and can be supplied as optional extras). The accumulator must not be subjected to any stress or load, in particular from the structure with which it is associated. Contact Olaer in case of mounting on the movable structures.

IT IS STRICTLY FORBIDDEN TO

- Weld, screw or rivet anything onto the accumulator body.
- Operate in any way that may alter the mechanical properties of the accumulator.
- Use the accumulator for construction purposes. (No stress or loading)
- To modify the accumulator without prior approval from the manufacturer.

GAS FILLING

For safety reasons, use only pure nitrogen, minimum 99.8% volume. In most of the cases the pre-charge pressure is between 0,9 P1 and 0,25 P2. Your local Olaer office can calculate the correct pre-charge pressure for your application. Olaer offers a range of devices for checking nitrogen pressure as well as pre-charging accumulators. *Please note that various adaptors are required to interface with different accumulator filling valves and nitrogen (N2) cylinder connections throughout the world.*

The part number defines the accumulator and the material construction. Information contained on the labeling/manufacturer's plate:

- Olaer logo
- Product description
- Date or year of manufacture
- Reference information of the accumulator
- Allowable temperature range of the accumulator

Additional information on certain models:

- Warning messages and safety instructions ("Danger", "Use nitrogen only" or similar message)
- Maximum inflation pressure P0 max in bar
- Allowable pressure amplitude P max in bar
- Fluid group (1 or 2 according to the Directive 97/23/EC)
- Total dry mass in kilogram

Maximum allowable operating pressure

The maximum pressure (PS) is indicated on the accumulator. Check that the maximum allowable pressure is greater than that of the hydraulic system. For any other pressure, you will have to contact Olaer.

Maximum allowable operating temperature

The temperature range (TS) is indicated on the accumulator. Check that the allowable temperature range covers the operating temperatures (environment and hydraulic fluid temperatures). For any other temperature, you will have to contact Olaer.

Maintenance

Any intervention, maintenance, repair must be carried out by a qualified and trained personnel.

Item	Spare parts
1	Bladder kit
2*	Bladder assembly
3*	Gas valve assembly
4	Gas valve cap
5	Fluid port assembly
6*	Anti extrusion ring
7*	Drain plug with seal ⁽¹⁾
8*	Seal kit

⁽¹⁾ For accumulators 10 to 50 liters before May 2009

* These parts are supplied as a kit with instructions.

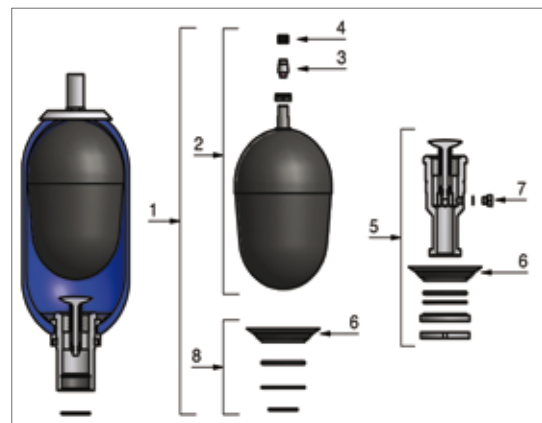

HOW TO ORDER THE BLADDER KIT

Example: For an accumulator EHV 50-330/90 01125
KIT EHV 50-330/90 01125

EC Regulation

The Regulation 97/23/CE has been applicable since 29/11/99 on a voluntary base, and has been mandatory since 29/05/2002.

EC type accumulators are delivered with instructions for operation and a declaration of conformity. Olaer designs and manufactures hydro-pneumatic accumulators for use in all countries and which comply with national regulations in force as ASME / selo...

WHAT YOU NEED TO KNOW

Directive 97/23/ EC is applicable from 29-11-1999 and mandatory from 29-05-2002.

Decree 99-1046, which applies to new machinery and the ministerial order of 15-03-2000, which applies to the operation of all machinery, transposed the directive into French domestic legislation.

- Free movement of machinery within the European Union.
- Group 2 fluid accumulators whose $V \leq 1$ L and $PS \leq 1000$ bar are not entitled to stamp EC marking.
- The EC marking should be accompanied by the identification number of the notified authority.

(1) OJ No C 246, 9. 9. 1993, p. 1 and OJ No C 207, 27. 7. 1994, p. 3.

(2) OJ No C 32, 19. 2. 1994, p. 10.

(3) Opinion of the European Parliament of 19 April 1994 (OJ No C 128, 9. 5. 1994, p. 61), common position of the Council of 29 March 1994 (OJ No C 147, 21. 5. 1994, p. 1), Decision of the European Parliament of 17 July 1994 (OJ No C 263, 9. 9. 1994, p. 68), Council Decision of 17 April 1997.



- in Fluid Energy Management

Global perspective

and local entrepreneurial flair



Olaer is a global player specialising in innovative, efficient system solutions for temperature optimisation and energy storage. Olaer develops, manufactures and markets products and systems for a number of different sectors, e.g. the aircraft, engineering, steel and mining industries, as well as for sectors such as oil and gas, contracting and transport, farming and forestry, renewable energy, etc.

All over the world, our products operate in the most diverse environments and applications. One constantly

repeated demand in the market is for optimal energy storage and temperature optimisation. We work at a local level with a whole world as our workplace – local entrepreneurial flair and a global perspective go hand in hand.

Our local presence, long experience and a wealth of knowledge combine with our cutting-edge expertise to give you the best possible conditions for making a professional choice.